

Acta Crystallographica Section E

Structure Reports

Online

ISSN 1600-5368

Aquabis(*o*-vanillinato- κ^2O,O')nickel(II)

Qiang Wang and Da-Qi Wang*

College of Chemistry and Chemical Engineering, Liaocheng University, Shandong 252059, People's Republic of China

Correspondence e-mail: wdq4899@163.com

Received 11 November 2007; accepted 21 December 2007

Key indicators: single-crystal X-ray study; $T = 298$ K; mean $\sigma(\text{C}-\text{C}) = 0.010$ Å; R factor = 0.062; wR factor = 0.157; data-to-parameter ratio = 14.6.

The Ni^{II} atom in the title complex, aquabis(2-formyl-6-methoxyphenolato- κ^2O,O')nickel(II), $[\text{Ni}(\text{C}_8\text{H}_7\text{O}_3)_2(\text{H}_2\text{O})]$, is five-coordinated by four O atoms from two *o*-vanillinate ligands and one water molecule in a slightly distorted square-pyramidal geometry ($\tau = 0.06$). In the crystal structure, the molecules are linked into dimers by intermolecular O—H...O hydrogen bonds.

Related literature

For general background, see: Meyer *et al.* (1982); Soules *et al.* (1988); Edwards *et al.* (1992); Asokan *et al.* (1998). For calculation of the τ parameter, see: Addison *et al.* (1984).

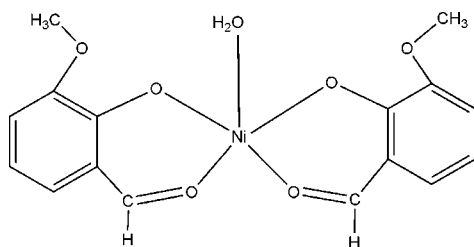

Experimental

Crystal data

 $[\text{Ni}(\text{C}_8\text{H}_7\text{O}_3)_2(\text{H}_2\text{O})]$ $M_r = 379.00$ Monoclinic, $P2_1/c$ $a = 9.4569$ (14) Å $b = 15.8320$ (19) Å $c = 11.1372$ (18) Å $\beta = 97.729$ (2)° $V = 1652.3$ (4) Å³ $Z = 4$ Mo $K\alpha$ radiation $\mu = 1.21$ mm⁻¹ $T = 298$ (2) K

0.43 × 0.40 × 0.15 mm

Data collection

Siemens SMART CCD area-detector diffractometer
Absorption correction: multi-scan (*SADABS*; Sheldrick, 1996)
 $T_{\min} = 0.625$, $T_{\max} = 0.840$ 8178 measured reflections
2909 independent reflections
1462 reflections with $I > 2\sigma(I)$
 $R_{\text{int}} = 0.083$

Refinement

 $R[F^2 > 2\sigma(F^2)] = 0.061$ $wR(F^2) = 0.157$ $S = 1.00$

2909 reflections

199 parameters

3 restraints

H-atom parameters constrained

 $\Delta\rho_{\text{max}} = 0.54$ e Å⁻³ $\Delta\rho_{\text{min}} = -1.08$ e Å⁻³

Table 1

Hydrogen-bond geometry (Å, °).

<i>D</i> —H... <i>A</i>	<i>D</i> —H	H... <i>A</i>	<i>D</i> ... <i>A</i>	<i>D</i> —H... <i>A</i>
O7—H2...O2 ⁱ	0.85	2.21	2.899 (5)	139
O7—H2...O3 ⁱ	0.85	2.21	2.929 (6)	143
O7—H3...O5 ⁱ	0.85	2.17	2.907 (5)	146
O7—H3...O6 ⁱ	0.85	2.25	2.906 (5)	134

Symmetry code: (i) $-x + 1, -y + 2, -z + 1$.

Data collection: *SMART* (Siemens, 1996); cell refinement: *SAINT* (Siemens, 1996); data reduction: *SAINT*; program(s) used to solve structure: *SHELXS97* (Sheldrick, 2008); program(s) used to refine structure: *SHELXL97* (Sheldrick, 2008); molecular graphics: *SHELXTL* (Sheldrick, 1997); software used to prepare material for publication: *SHELXTL*.

The authors acknowledge the financial support of the Shandong Province Science Foundation, and the State Key Laboratory of Crystalline Materials, Shandong University, People's Republic of China.

Supplementary data and figures for this paper are available from the IUCr electronic archives (Reference: BV2085).

References

- Addison, A. W., Rao, T. N., Reedijk, J., van Rijn, J. & Verschoor, G. C. (1984). *J. Chem. Soc. Dalton Trans.* pp. 1349–1356.
- Asokan, A., Varghese, B., Caneschi, A. & Manoharan, P. T. (1998). *Inorg. Chem.* **37**, 228–232.
- Edwards, A. J., Hoskins, B. F., Kachab, E. H., Markiewicz, A., Murray, K. S. & Robson, R. (1992). *Inorg. Chem.* **31**, 3585–3591.
- Meyer, A., Gleizes, A., Girerd, J. J., Verdager, M. & Kahn, O. (1982). *Inorg. Chem.* **21**, 1729–1739.
- Sheldrick, G. M. (1996). *SADABS*. University of Göttingen, Germany.
- Sheldrick, G. M. (1997). *SHELXTL*. Version 5.1. Bruker AXS Inc., Madison, Wisconsin, USA.
- Sheldrick, G. M. (2008). *Acta Cryst.* **A64**, 112–122.
- Siemens (1996). *SMART* and *SAINT*. Siemens Analytical X-ray Instruments Inc., Madison, Wisconsin, USA.
- Soules, R., Dahan, F., Laurent, J. P. & Castan, P. (1988). *J. Chem. Soc. Dalton Trans.* pp. 587–590.

supplementary materials

Acta Cryst. (2008). E64, m298 [doi:10.1107/S1600536807068183]

Aquabis(*o*-vanillinato- κ^2O,O')nickel(II)

Q. Wang and D.-Q. Wang

Comment

The structural and magnetic properties of binuclear and polynuclear nickel(II) complexes with various bridging ligands have received considerable attention in the past three decades (Meyer *et al.*, 1982; Soules *et al.*, 1988; Edwards *et al.*, 1992; Asokan *et al.*, 1998). In this paper, we report here the synthesis and crystal structure of the title complex, a new nickel complex.

The molecular structure of the title complex, (I), is shown in Fig. 1. The Ni^{II} atom is five-coordinated in which four oxygen O(1), O(2), O(4), O(5) atoms from two *o*-vanillin ligands and one water molecule in a slightly distorted square pyramidal geometry, the tau value is 0.06 (Addison *et al.*, 1984). Ni(1), O(1), C(1), C(2), C(3), O(2) and Ni(1), O(4), C(9), C(10), C(11), O(5) form two six-membered chelating rings, which are essentially coplanar with a dihedral angle of 6.7 (0.19)°.

As seen in Fig. 2, the molecules are linked into dimers by intermolecular O—H...O hydrogen bonds (Table 1).

Experimental

Amounts of 304.3 mg (2 mmol) of *o*-vanillin and 80.00 mg (2 mmol) of NaOH were stirred into 30 ml absolute ethanol under room temperature for 20 minutes, nickel chloride hexahydrate in the amount of 237.7 mg (1 mmol) was added, and the mixture was heated with stirring for 7 h and then filtered. The well shaped green polyhedral crystals of [Ni(C₈H₇O₃)₂H₂O] for structure determination and characterization were separated from the mother liquor by slow evaporation at room temperature after two weeks.

Refinement

All H-atoms were positioned geometrically and refined using a riding model, with C—H (methyl) 0.96, C—H (aromatic) 0.93, C—H 0.93 Å (methylene), O—H 0.85 Å (water), with $U_{\text{iso}}(\text{H}) = 1.2U_{\text{eq}}(\text{C})$.

Figures

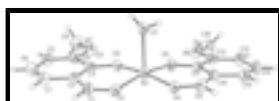

Fig. 1. The structure of the title complex, showing 30% probability displacement ellipsoids and the atom-numbering scheme.

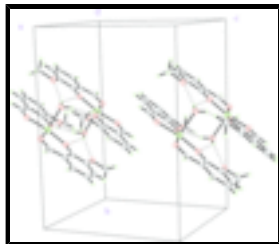

Fig. 2. The crystal packing of the title compound, viewed approximately along the *bc* plane.

aquabis(2-formyl-6-methoxyphenolato- κ^2O,O')nickel(II)

Crystal data

[Ni(C₈H₇O₃)₂(H₂O)]

$M_r = 379.00$

Monoclinic, $P2_1/c$

Hall symbol: -P 2ybc

$a = 9.4569$ (14) Å

$b = 15.8320$ (19) Å

$c = 11.1372$ (18) Å

$\beta = 97.729$ (2)°

$V = 1652.3$ (4) Å³

$Z = 4$

$F_{000} = 784$

$D_x = 1.524$ Mg m⁻³

Mo $K\alpha$ radiation

$\lambda = 0.71073$ Å

Cell parameters from 1614 reflections

$\theta = 2.5$ – 27.7°

$\mu = 1.21$ mm⁻¹

$T = 298$ (2) K

Block, green

$0.43 \times 0.40 \times 0.15$ mm

Data collection

Siemens SMART CCD area-detector diffractometer

Radiation source: fine-focus sealed tube

Monochromator: graphite

$T = 298$ (2) K

φ and ω scans

Absorption correction: multi-scan (SADABS; Sheldrick, 1996)

$T_{\min} = 0.625$, $T_{\max} = 0.840$

8178 measured reflections

2909 independent reflections

1462 reflections with $I > 2\sigma(I)$

$R_{\text{int}} = 0.083$

$\theta_{\text{max}} = 25.0^\circ$

$\theta_{\text{min}} = 2.2^\circ$

$h = -11 \rightarrow 11$

$k = -10 \rightarrow 18$

$l = -13 \rightarrow 12$

Refinement

Refinement on F^2

Least-squares matrix: full

$R[F^2 > 2\sigma(F^2)] = 0.062$

$wR(F^2) = 0.157$

$S = 1.00$

2909 reflections

Secondary atom site location: difference Fourier map

Hydrogen site location: inferred from neighbouring sites

H-atom parameters constrained

$w = 1/[\sigma^2(F_o^2) + (0.0683P)^2]$

where $P = (F_o^2 + 2F_c^2)/3$

$(\Delta/\sigma)_{\text{max}} < 0.001$

$\Delta\rho_{\text{max}} = 0.54$ e Å⁻³

199 parameters

$$\Delta\rho_{\min} = -1.08 \text{ e } \text{\AA}^{-3}$$

3 restraints

Extinction correction: none

Primary atom site location: structure-invariant direct methods

Special details

Geometry. All e.s.d.'s (except the e.s.d. in the dihedral angle between two l.s. planes) are estimated using the full covariance matrix. The cell e.s.d.'s are taken into account individually in the estimation of e.s.d.'s in distances, angles and torsion angles; correlations between e.s.d.'s in cell parameters are only used when they are defined by crystal symmetry. An approximate (isotropic) treatment of cell e.s.d.'s is used for estimating e.s.d.'s involving l.s. planes.

Refinement. Refinement of F^2 against ALL reflections. The weighted R -factor wR and goodness of fit S are based on F^2 , conventional R -factors R are based on F , with F set to zero for negative F^2 . The threshold expression of $F^2 > \sigma(F^2)$ is used only for calculating R -factors(gt) *etc.* and is not relevant to the choice of reflections for refinement. R -factors based on F^2 are statistically about twice as large as those based on F , and R -factors based on ALL data will be even larger.

Fractional atomic coordinates and isotropic or equivalent isotropic displacement parameters (\AA^2)

	<i>x</i>	<i>y</i>	<i>z</i>	$U_{\text{iso}}^*/U_{\text{eq}}$
Ni1	0.67982 (8)	0.96568 (5)	0.38774 (6)	0.0453 (3)
O1	0.8808 (4)	0.9428 (2)	0.4415 (3)	0.0453 (3)
O2	0.6193 (4)	0.8834 (2)	0.4980 (3)	0.0513 (11)
O3	0.4899 (6)	0.7887 (3)	0.6400 (4)	0.0692 (14)
O4	0.7481 (4)	1.0350 (2)	0.2593 (3)	0.0453 (3)
O5	0.4873 (4)	0.9690 (2)	0.3093 (3)	0.0496 (11)
O6	0.2167 (5)	0.9542 (3)	0.2415 (4)	0.0608 (12)
O7	0.6836 (4)	1.0859 (2)	0.5067 (3)	0.0453 (3)
H2	0.6050	1.1043	0.4699	0.068*
H3	0.6619	1.0821	0.5782	0.068*
C1	0.9283 (7)	0.8990 (4)	0.5329 (6)	0.0616 (19)
H1	1.0270	0.8976	0.5528	0.074*
C2	0.8499 (7)	0.8524 (4)	0.6073 (6)	0.0543 (18)
C3	0.7005 (7)	0.8465 (4)	0.5862 (6)	0.0475 (16)
C4	0.6359 (9)	0.7939 (4)	0.6677 (6)	0.0586 (19)
C5	0.7127 (11)	0.7527 (5)	0.7618 (7)	0.082 (3)
H5	0.6664	0.7188	0.8126	0.098*
C6	0.8604 (11)	0.7610 (5)	0.7822 (8)	0.090 (3)
H6	0.9123	0.7333	0.8474	0.108*
C7	0.9297 (9)	0.8095 (5)	0.7074 (7)	0.075 (2)
H7	1.0285	0.8147	0.7214	0.090*
C8	0.4138 (9)	0.7343 (4)	0.7120 (7)	0.093 (3)
H8A	0.4531	0.6784	0.7123	0.139*
H8B	0.3149	0.7327	0.6783	0.139*
H8C	0.4225	0.7554	0.7935	0.139*
C9	0.6688 (7)	1.0686 (4)	0.1745 (5)	0.0551 (17)
H9	0.7142	1.1025	0.1231	0.066*
C10	0.5204 (7)	1.0624 (4)	0.1462 (5)	0.0465 (16)
C11	0.4375 (7)	1.0112 (3)	0.2125 (5)	0.0419 (15)

supplementary materials

C12	0.2881 (7)	1.0062 (4)	0.1720 (6)	0.0490 (16)
C13	0.2275 (8)	1.0497 (4)	0.0718 (6)	0.0614 (19)
H13	0.1302	1.0444	0.0462	0.074*
C14	0.3087 (9)	1.1010 (4)	0.0087 (6)	0.071 (2)
H14	0.2659	1.1308	-0.0585	0.086*
C15	0.4511 (9)	1.1083 (4)	0.0442 (6)	0.064 (2)
H15	0.5047	1.1438	0.0014	0.077*
C16	0.0696 (7)	0.9382 (5)	0.2025 (7)	0.088 (3)
H16A	0.0191	0.9909	0.1918	0.132*
H16B	0.0309	0.9050	0.2625	0.132*
H16C	0.0594	0.9081	0.1271	0.132*

Atomic displacement parameters (\AA^2)

	U^{11}	U^{22}	U^{33}	U^{12}	U^{13}	U^{23}
Ni1	0.0487 (5)	0.0459 (5)	0.0406 (5)	-0.0023 (4)	0.0037 (3)	0.0054 (4)
O1	0.0487 (5)	0.0459 (5)	0.0406 (5)	-0.0023 (4)	0.0037 (3)	0.0054 (4)
O2	0.058 (3)	0.050 (2)	0.044 (3)	0.012 (2)	-0.001 (2)	0.014 (2)
O3	0.092 (4)	0.050 (3)	0.069 (3)	-0.006 (3)	0.026 (3)	0.013 (2)
O4	0.0487 (5)	0.0459 (5)	0.0406 (5)	-0.0023 (4)	0.0037 (3)	0.0054 (4)
O5	0.055 (3)	0.048 (2)	0.045 (2)	-0.005 (2)	0.003 (2)	0.012 (2)
O6	0.051 (3)	0.074 (3)	0.055 (3)	-0.011 (3)	0.001 (2)	0.005 (2)
O7	0.0487 (5)	0.0459 (5)	0.0406 (5)	-0.0023 (4)	0.0037 (3)	0.0054 (4)
C1	0.054 (5)	0.065 (5)	0.060 (5)	0.010 (4)	-0.013 (4)	0.001 (4)
C2	0.062 (5)	0.048 (4)	0.052 (4)	0.018 (4)	0.002 (4)	0.002 (3)
C3	0.063 (5)	0.039 (4)	0.041 (4)	0.010 (3)	0.010 (4)	-0.007 (3)
C4	0.091 (6)	0.040 (4)	0.046 (4)	0.008 (4)	0.014 (4)	0.001 (3)
C5	0.135 (8)	0.061 (5)	0.052 (5)	0.020 (5)	0.017 (5)	0.013 (4)
C6	0.113 (8)	0.075 (6)	0.080 (6)	0.036 (6)	0.008 (6)	0.004 (5)
C7	0.075 (6)	0.083 (6)	0.063 (5)	0.023 (5)	-0.008 (4)	0.007 (5)
C8	0.137 (8)	0.058 (5)	0.094 (6)	-0.015 (5)	0.051 (6)	0.007 (4)
C9	0.059 (5)	0.057 (4)	0.049 (4)	-0.004 (4)	0.007 (4)	0.006 (3)
C10	0.059 (5)	0.040 (3)	0.039 (4)	0.004 (3)	0.001 (3)	0.005 (3)
C11	0.056 (5)	0.034 (3)	0.034 (4)	0.002 (3)	0.000 (3)	-0.003 (3)
C12	0.056 (5)	0.045 (4)	0.046 (4)	0.000 (3)	0.003 (4)	-0.002 (3)
C13	0.068 (5)	0.068 (5)	0.045 (4)	0.009 (4)	-0.005 (4)	0.009 (4)
C14	0.090 (6)	0.063 (5)	0.055 (5)	0.007 (5)	-0.015 (4)	0.011 (4)
C15	0.092 (6)	0.052 (4)	0.047 (4)	-0.008 (4)	0.008 (4)	0.004 (3)
C16	0.047 (5)	0.122 (7)	0.092 (6)	-0.008 (5)	0.001 (4)	0.012 (5)

Geometric parameters (\AA , $^\circ$)

Ni1—O5	1.912 (4)	C5—H5	0.9300
Ni1—O2	1.929 (4)	C6—C7	1.364 (10)
Ni1—O1	1.949 (4)	C6—H6	0.9300
Ni1—O4	1.978 (4)	C7—H7	0.9300
Ni1—O7	2.316 (3)	C8—H8A	0.9600
O1—C1	1.263 (7)	C8—H8B	0.9600
O2—C3	1.301 (7)	C8—H8C	0.9600

O3—C4	1.377 (8)	C9—C10	1.400 (8)
O3—C8	1.434 (7)	C9—H9	0.9300
O4—C9	1.244 (6)	C10—C11	1.405 (8)
O5—C11	1.302 (6)	C10—C15	1.431 (8)
O6—C12	1.369 (7)	C11—C12	1.426 (8)
O6—C16	1.423 (7)	C12—C13	1.370 (8)
O7—H2	0.8502	C13—C14	1.375 (9)
O7—H3	0.8502	C13—H13	0.9300
C1—C2	1.395 (9)	C14—C15	1.357 (9)
C1—H1	0.9300	C14—H14	0.9300
C2—C3	1.404 (8)	C15—H15	0.9300
C2—C7	1.431 (9)	C16—H16A	0.9600
C3—C4	1.428 (8)	C16—H16B	0.9600
C4—C5	1.359 (9)	C16—H16C	0.9600
C5—C6	1.391 (10)		
O5—Ni1—O2	87.93 (16)	C6—C7—C2	119.8 (8)
O5—Ni1—O1	167.31 (16)	C6—C7—H7	120.1
O2—Ni1—O1	92.25 (16)	C2—C7—H7	120.1
O5—Ni1—O4	92.17 (16)	O3—C8—H8A	109.5
O2—Ni1—O4	171.17 (16)	O3—C8—H8B	109.5
O1—Ni1—O4	85.73 (16)	H8A—C8—H8B	109.5
O5—Ni1—O7	100.30 (15)	O3—C8—H8C	109.5
O2—Ni1—O7	99.99 (14)	H8A—C8—H8C	109.5
O1—Ni1—O7	92.17 (14)	H8B—C8—H8C	109.5
O4—Ni1—O7	88.68 (14)	O4—C9—C10	128.7 (6)
C1—O1—Ni1	125.2 (4)	O4—C9—H9	115.7
C3—O2—Ni1	126.1 (4)	C10—C9—H9	115.7
C4—O3—C8	118.3 (6)	C9—C10—C11	122.4 (6)
C9—O4—Ni1	124.3 (4)	C9—C10—C15	118.8 (6)
C11—O5—Ni1	127.5 (4)	C11—C10—C15	118.8 (6)
C12—O6—C16	118.1 (5)	O5—C11—C10	124.5 (6)
Ni1—O7—H2	93.5	O5—C11—C12	117.7 (5)
Ni1—O7—H3	119.4	C10—C11—C12	117.8 (6)
H2—O7—H3	99.8	O6—C12—C13	125.4 (6)
O1—C1—C2	127.6 (6)	O6—C12—C11	113.5 (5)
O1—C1—H1	116.2	C13—C12—C11	121.2 (6)
C2—C1—H1	116.2	C12—C13—C14	120.8 (7)
C1—C2—C3	122.6 (6)	C12—C13—H13	119.6
C1—C2—C7	116.6 (7)	C14—C13—H13	119.6
C3—C2—C7	120.8 (7)	C15—C14—C13	120.2 (7)
O2—C3—C2	125.1 (6)	C15—C14—H14	119.9
O2—C3—C4	118.8 (6)	C13—C14—H14	119.9
C2—C3—C4	116.1 (6)	C14—C15—C10	121.2 (6)
C5—C4—O3	124.0 (7)	C14—C15—H15	119.4
C5—C4—C3	122.7 (8)	C10—C15—H15	119.4
O3—C4—C3	113.2 (6)	O6—C16—H16A	109.5
C4—C5—C6	120.0 (8)	O6—C16—H16B	109.5
C4—C5—H5	120.0	H16A—C16—H16B	109.5
C6—C5—H5	120.0	O6—C16—H16C	109.5

supplementary materials

C7—C6—C5	120.6 (8)	H16A—C16—H16C	109.5
C7—C6—H6	119.7	H16B—C16—H16C	109.5
C5—C6—H6	119.7		

Hydrogen-bond geometry (Å, °)

<i>D—H···A</i>	<i>D—H</i>	<i>H···A</i>	<i>D···A</i>	<i>D—H···A</i>
O7—H2···O2 ⁱ	0.85	2.21	2.899 (5)	139
O7—H2···O3 ⁱ	0.85	2.21	2.929 (6)	143
O7—H3···O5 ⁱ	0.85	2.17	2.907 (5)	146
O7—H3···O6 ⁱ	0.85	2.25	2.906 (5)	134

Symmetry codes: (i) $-x+1, -y+2, -z+1$.

Fig. 1

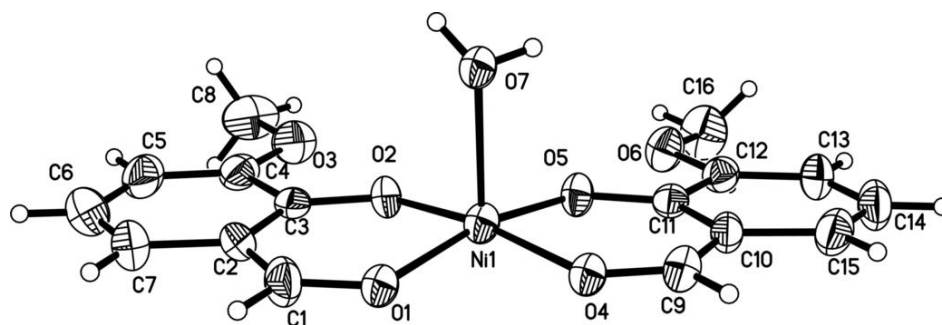

Fig. 2

