

# A high-pressure and controlled-flow gas system for catalysis research

Vladimir Martis,<sup>a,b</sup> Andrew M. Beale,<sup>c</sup> Dirk Detollenaere,<sup>a</sup> Dipanjan Banerjee,<sup>a</sup> Martine Moroni,<sup>d</sup> Fabrice Gosselin<sup>e</sup> and Wim Bras<sup>a\*</sup>

<sup>a</sup>Netherlands Organisation for Scientific Research (NWO), Dutch–Belgium Beamline, European Synchrotron Radiation Facility, BP 220, 6 Rue Jules Horowitz, 38043 Grenoble, France, <sup>b</sup>Department of Chemistry, University College London, 20 Gordon Street, London WC1H 0AJ, UK, <sup>c</sup>Inorganic Chemistry and Catalysis, Debye Institute for NanoMaterials Science, Utrecht University, Sorbonnelaan 16, 3584 CA Utrecht, The Netherlands, <sup>d</sup>European Synchrotron Radiation Facility, BP 220, 6 Rue Jules Horowitz, 38043 Grenoble, France, and <sup>e</sup>Serv Instrumentation, ZI Broteau Nord, 69540 Irigny, France. \*E-mail: wim.bras@esrf.eu

A high-pressure gas rig for *in situ* catalytic reactions at X-ray absorption spectroscopy beamline (BM26A) has been developed. The rig enables catalysts to be studied in a variety of cells under well controlled and industrially relevant operation conditions. A large variety of gas mixtures can be generated and pressures of up to 50 bar with dry gas and 20 bar with wet gas (steam) can be obtained. Analyses of reaction products can be performed using an on-line mass spectrometer.

© 2014 International Union of Crystallography

**Keywords:** catalysis; XAS; XRD; high-pressure gas system; steam.

## 1. Introduction

*In situ* time-resolved X-ray absorption spectroscopy (XAS) and diffraction (XRD) experiments are routinely applied to study the local structure of materials/catalysts. However, in catalysis research it is of interest to perform such experiments under *in operando* conditions, *i.e.* at appropriate temperatures, pressures and gas flows, in order to gain direct insight into the active state of the catalyst which is difficult by only studying the structure of spent catalysts (Beale *et al.*, 2005). Understanding the structure–activity relationships leads to fundamental understanding of catalysis and can provide the basis for rational design of improved catalysts (de Smit *et al.*, 2009; Rhodes *et al.*, 1995) and CO<sub>2</sub> sorption processes (Walspurger *et al.*, 2011). In order to eliminate issues related to transport, safety and reliability, a high-pressure gas rig with well controlled flows has been designed and permanently installed on the XAS beamline (BM26A) at the ESRF (Nikitenko *et al.*, 2008). The design is inspired by earlier installations at several facilities for XRD and XAFS studies (Llewellyn *et al.*, 2009; Hill, 2013; Jacques *et al.*, 2009; van Beek *et al.*, 2011). The system is equipped with standardized Swagelok connectors that allow users to connect their own preferred sample cells or use one of the beamline capillary cells. The pressure/temperature readings and valve controls are fully automated and allow rapid and modulated gas mixture changes.

## 2. High-pressure gas rig design

The main design parameters were: (i) safe and easy operation; (ii) a large range of catalytically relevant gases (excluding H<sub>2</sub>S due to contamination issues); (iii) reliable mixing and avoidance of contamination when gas mixtures are changed; and (iv) rapid switching between different pressures and gas mixtures with a small dead volume.

The modular gas manifolds consist of two panels which are fixed outside the experimental hutch. Different sized gas cylinders connect to a panel with four Tescom pressure regulators. The gas cylinders are connected to pressure regulators *via* Swagelok FM double-braided metal flexible hoses and fast connectors rated up to 213 bar. From each panel three gas lines (1/8 inch 316 stainless steel) connect to the gas handling system. Each gas line is dedicated to either asphyxiating, oxidizing, flammable, corrosive or toxic gas. NO and NO<sub>2</sub> gas bottles are kept in a separate ventilated gas cabinet with leak detection systems. A schematic drawing of a gas line fitted on modular gas manifolds panels is shown in Fig. 1. Each line is fitted with a check valve (CV) and two Swagelok T-fittings placed before and after the pressure regulator. The CV permits one-directional flow. The T-fitting before the CV is for purging the line, whereas the one after is for venting, *i.e.* relieving regulator pressure. All gas lines can be purged simultaneously. The purging of the gas lines between experiments is a normal procedure from a safety point of view as well as being part of experimental hygiene.

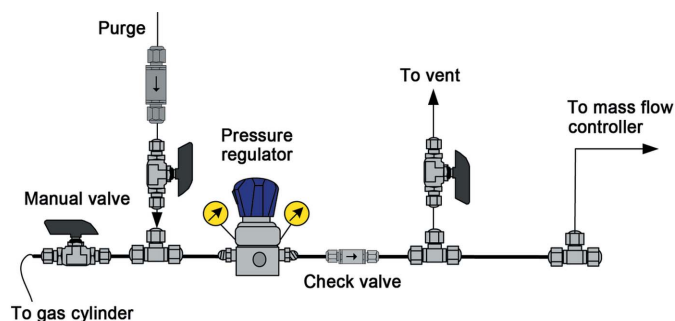

**Figure 1**  
Scheme of a typical gas line fitted onto modular gas manifolds panels. See the text for further explanation.

The operation and flow control system is fitted on three panels inside the experimental hutch, as shown in Fig. 2. Panel 1 contains two groups of three Brooks 5850S mass flow controllers (MFCs) which are fed into separate mixing cylinders. These have a volume of  $\sim 4$  ml and are filled with SiC. They are separated by a locked manual valve (MV). Every single MFC in each group is dedicated to a family of gases and flow rates. MFC1 is for high flows [100 s.c.c.m. (standard cubic centimeter per minute)] of He, Ar, N<sub>2</sub>; MFC2 is for medium flows ( $\sim 20$  s.c.c.m.) of O<sub>2</sub> and N<sub>2</sub>O; MFC3 for low flows (10 s.c.c.m.) of CO or CO<sub>2</sub>; MFC4 ( $\sim 10$  s.c.c.m.) for NO and NO<sub>2</sub>; MFC5 (20–30 s.c.c.m.) for CH<sub>4</sub>, C<sub>3</sub>H<sub>6</sub>, C<sub>3</sub>H<sub>8</sub> and C<sub>2</sub>H<sub>4</sub>; and MFC6 for high flows (100 s.c.c.m.) of H<sub>2</sub>. Each MFC is pre-set with several (changeable) pre-programmed calibration curves for pure gases and gas mixtures and also has an option for manual configuration of calibration curves. The pressure build-up in the sample cell takes 8 bar min<sup>-1</sup> and rapid pressure modulation can be achieved *via* the four-way fast-switching valve (SV1) which is used for switching between gases at desired pressures. Pressure in tubing and reaction cells (1–50 bar) is controlled by two Brooks 5866 back pressure controllers (BPCs) (panel 3 in Fig. 2). The BPCs can be bypassed for atmospheric pressure experiments. Pressure is also monitored by pressure transducers (PTs) which are fixed before and after a cell.

For experiments requiring steam a vaporizer or saturator can be connected *via* SV2 placed inside the heating box (panel 2 in Fig. 2). The benefit of using two switching valves is that a mixture of steam and gases can be produced in a closed loop without interfering with the rest of the set-up. The wet gas is led out of the cell to the exhaust in order to obtain a good quality steam/dry-gas mixture before the mixture is allowed into the reaction cell. During this period dry gas from the other gas line can flow to the cell and activate the sample. The steam system can be operated up to 513 K and is thermally insulated in order to prevent condensation. Heaters and thermal controllers are placed at several critical positions in order to avoid cold spots. To avoid damage due to wet gas, condensers are fitted before the BPCs. The maximum pressure that can be achieved in the reaction cells using steam is 20 bar.

An ESS GeneSys mass spectrometer is available for on-line analysis of the reaction products.

### 3. Operational control

The rig is remotely controlled using software running on a Windows computer. Data communication is *via* an RS-232 interface, allowing the setting of flow rates for MFCs, pressures for BPCs, stop flows in the case of unexpected events using pneumatic valves (PVs) installed after MFCs, temperatures in the lines and heating box when a steamer is used, and fast switching between gases using SVs, and display pressures from PTs. In addition it records the system purges.

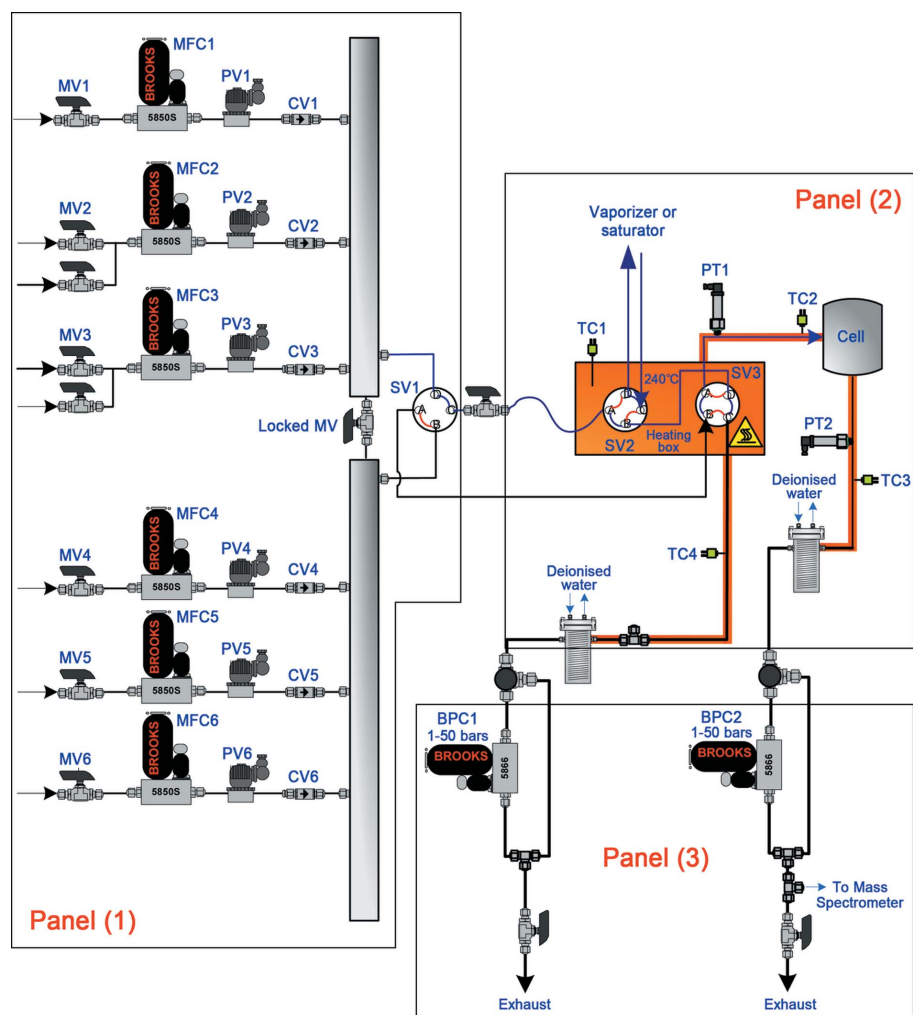

**Figure 2**  
Scheme of the operation and control flow system fitted on three panels. For explanation see the text.

O. Safanova, G. Sankar, E. Hensen, A. M. J. van der Eerden, W. Haije, P. D. Cobden and G. Luijckx are acknowledged for design advice and useful discussions. B. M. Weckhuijsen, W. Haije and E. Hensen are acknowledged for financial support.

### References

- Beale, A. M., van der Eerden, A. M. J., Kervinen, K., Newton, M. A. & Weckhuijsen, B. M. (2005). *Chem. Commun.* **24**, 3015–3017.
- Beek, W. van, Safanova, O. V., Wiker, G. & Emerich, H. (2011). *Phase Transit.* **84**, 726–732.
- Hill, A. H. (2013). *J. Appl. Cryst.* **46**, 570–572.
- Jacques, S. D. M., Leynaud, O., Strusevich, D., Stukas, P., Barnes, P., Sankar, G., Sheehy, M., O'Brien, M. G., Iglesias-Juez, A. & Beale, A. M. (2009). *Catal. Today*, **145**, 204–212.
- Llewellyn, P. L., Horcajada, P., Maurin, G., Devic, T., Rosenbach, N., Bourrelly, S., Serre, C., Vincent, D., Loera-Serna, S., Filinchuk, Y. & Ferey, G. (2009). *J. Am. Chem. Soc.* **131**, 13002–13008.
- Nikitenko, S., Beale, A. M., van der Eerden, A. M. J., Jacques, S. D. M., Leynaud, O., O'Brien, M. G., Detollenaere, D., Kaptein, R., Weckhuijsen, B. M. & Bras, W. (2008). *J. Synchrotron Rad.* **15**, 632–640.
- Rhodes, C., Hutchings, G. J. & Ward, A. M. (1995). *Catal. Today*, **23**, 43–58.
- Smit, E. de, Beale, A. M., Nikitenko, S. & Weckhuijsen, B. M. (2009). *J. Catal.* **262**, 244–256.
- Walspurger, S., de Munck, S., Cobden, P. D., Haije, W. G., van den Brink, R. W. & Safanova, O. V. (2011). *Energy Proc.* **4**, 1162–1167.